

HIGH SECURITY SEAL

FORT CONTAINER SEAL 82 (FCS 82)

Container Bolt Seal

Two colour and wavy surface for defined visibility and extra security.

Fort Container Seal 82 is a Mega Fortris patented two-colour container bolt seal. This seal complies to ISO 17712 and CTPAT with clear evidence of tampering from its innovatively designed anti-spinning pin and barrel. These seals include the BioSphere bio-additive.

To provide eco-conscious solutions on a wide array of applications, all Mega Fortris' security seal product lines with plastic content will include the BioSphere bio-additive from 13th May 2024.

Applications:

- Containers
- Trucks
- Trailers
- Rail Cars



Our biodegradable plastic additives go deeper, allowing microbes to consume the C-C bonds within plastic's structure at a macromolecular level. This increases the surface area of plastic products and enables plastophilic microbes to attach to the polymer's newfound cavities. So, unlike regular plastic that can sit in a landfill for hundreds or thousands of years, plastic enhanced with BioSphere attracts over 600 different types of microbes that effectively digest and consume it.

PREVENTION · PROTECTION · PEACE OF MIND



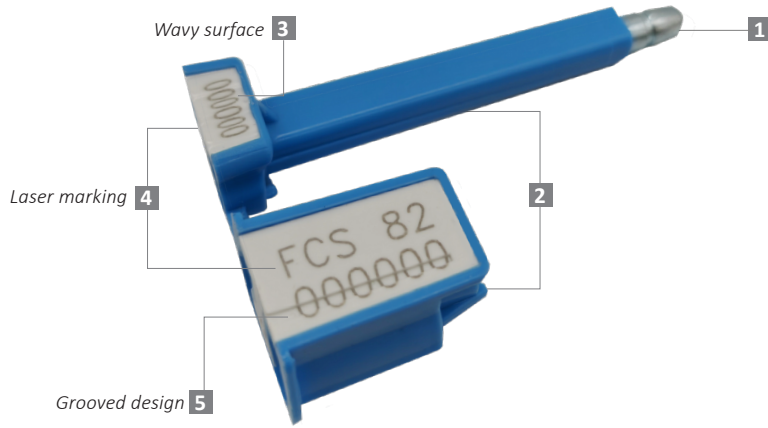

LASER MARKING OPTION

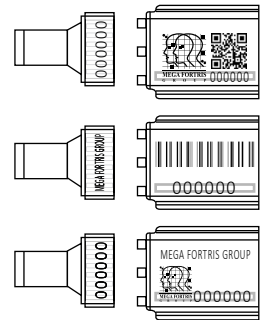

VIEW APPLICATION GIF

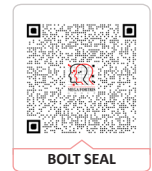

- 1 The Fort Container Seal 82 comes with an anti-spinning design that the locking mechanism allows only one-way entry and hinders friction from external force.
- 2 The pin and bush are moulded in high-impact PP material to form into a durable pin and plastic barrel while withstanding extreme weather conditions of -20°C to 80°C. Pin and barrel are paired engraved for easier handling.
- 3 Two colours on the pin and barrel improve laser markings definition, visibility, and identification. Additional wavy printing surface on pin gives clear evidence of tampering or removal of identifiers.
- 4 Irreversible identifiers such as name, logo, barcode, serial number and QR code are laser-marked on the pin and barrel to prevent parts substitution or replacement.
- 5 Grooved design on the plastic barrel prevents tampering on the identifier.
- 6 An optional transparent cover on the barrel further secures the identifier and provides high visibility.
- 7 These seals include the BioSphere bio-additive.
- 8 The seal is designed, tested and certified ISO 17712:2013.

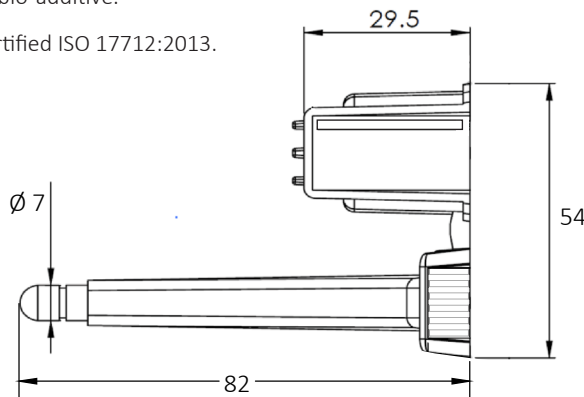

TECHNICAL SPECIFICATIONS

PRODUCT - FORT CONTAINER SEAL 82 (FCS 82)

Code	Material	Locking Length	Pin Diameter	Tensile Strength	Marking Area	Max Marking Digits
FCS 82	Plastic : High-impact Polypropylene (PP) Pin & Bush : Hardened Steel	57 mm (2.2 in)	Ø 7 mm (0.3 in)	≥1000 kgf (≥2204.6 lbf)	Pin: 7.5 x 13.8 mm (0.3 x 0.6 in) Barrel: 14.5 x 28 mm (0.6 x 1.1 in)	Serial no : 8 Barcode : 8

PACKAGING

Carton	Quantity	Dimensions (mm)	Gross Weight (kg)	Volume (m ³)	Standard Solid Colours
Outer	25 sets x 10 pcs	485 x 335 x 162 (19.1 x 13.2 x 6.4 in)	13.1 (28.9 lb)	0.026 (0.9 cu.ft.)	Body : WH BL YL GN OR RD BK

Marking flap : WH

For colour customisations, kindly contact us for further information.

Updated Date : 30 July 2024