



**MEGA FORTRIS**  
G R O U P

## **HIGH SECURITY SEAL** **MAXI CABLE LOCK ZINC 500 (MCLZ 500)**

**Pull-Tight Barrier Seal**

### ***Bright colours for defined identification.***

Maxi Cable Lock Zinc 500 is high-security cable seal that complies to ISO 17712 and CTPAT with a special entry point designed to prevent tampering attacks. It is strong and durable to secure high-value assets.

These seals include the BioSphere bio-additive.

To provide eco-conscious solutions on a wide array of applications, all Mega Fortris' security seal product lines with plastic content will include the BioSphere bio-additive from 13th May 2024.

#### **Applications:**

- Containers
- Trucks
- Trailers
- Rail Cars



Our biodegradable plastic additives go deeper, allowing microbes to consume the C-C bonds within plastic's structure at a macromolecular level. This increases the surface area of plastic products and enables plastophilic microbes to attach to the polymer's newfound cavities. So, unlike regular plastic that can sit in a landfill for hundreds or thousands of years, plastic enhanced with BioSphere attracts over 600 different types of microbes that effectively digest and consume it.

**PREVENTION · PROTECTION · PEACE OF MIND**



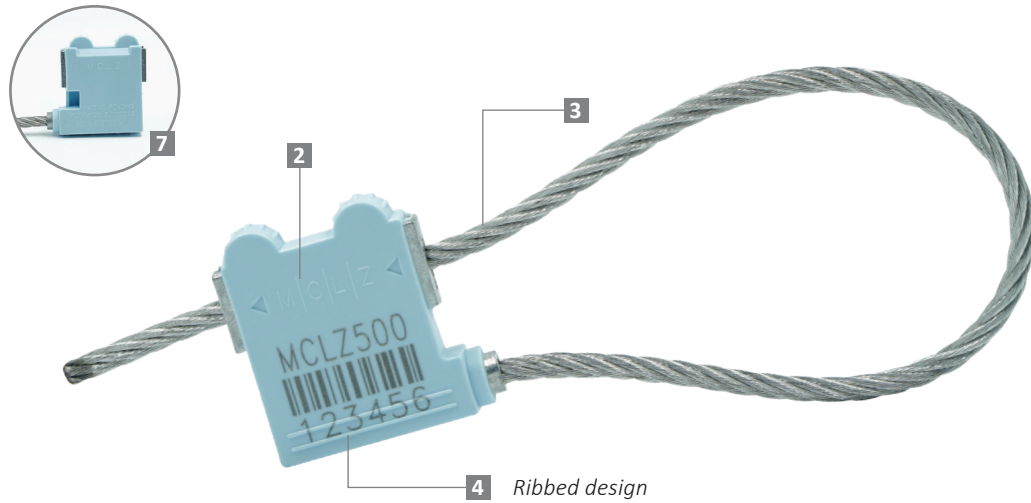

LASER MARKING OPTION



VIEW APPLICATION VIDEO



- 1 Unique to the security seal industry, this 3rd generation high-security cable seal features a lock body design that is non-linear and provides evidence of tampering.
- 2 High-impact PP plastic with vibrant pastel colour is moulded over the zinc lock cover to enable distinct colour coding and laser marking of identifiers such as name, logo, barcode, serial number and QR code.
- 3 The non-preformed galvanised steel wire unravels upon cutting to show clear evidence of tampering.
- 4 Ribbed design on the body prevents tampering on the identifier.
- 5 These seals include the BioSphere bio-additive.
- 6 Plastic material can withstand extreme weather conditions, -20°C to 80°C.
- 7 The seal is designed, tested and certified ISO 17712:2013.

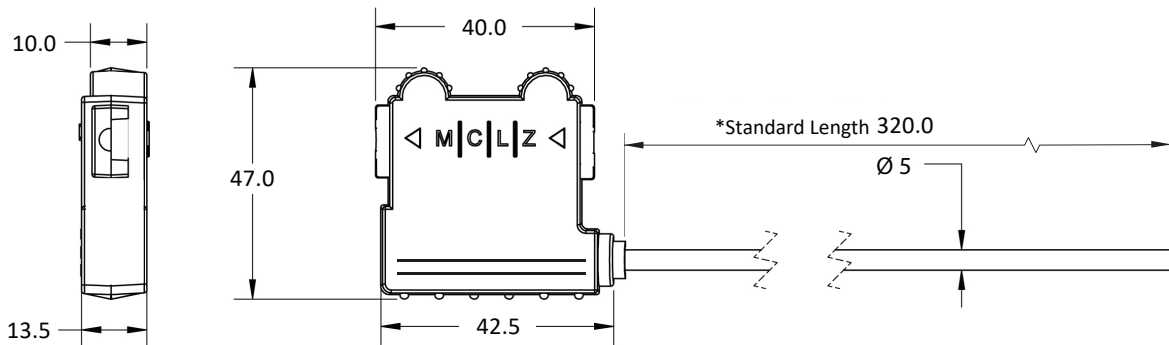

TECHNICAL SPECIFICATIONS

\*Customisable cable length upon request.

PRODUCT - MAXI CABLE LOCK ZINC 500 (MCLZ 500)

Code	Material	Cable Length	Cable Diameter	Tensile Strength	Marking Area	Max Marking Digits
MCLZ 500	Body : Zinc Plastic : Polypropylene (PP) Locking Component : Hardened Steel Cable : Galvanised Steel Wire	320 mm (12.6 in)	Ø 5 mm (0.2 in)	≥1000 kgf (≥2204.6 lbf)	25 x 30 mm (1.0 x 1.2 in)	Serial no : 8 Barcode : 8

PACKAGING

Carton	Quantity	Dimensions (mm)	Gross Weight (kg)	Volume (m <sup>3</sup> )	Standard Pastel Colours
Inner	100	450 x 250 x 135 (17.7 x 9.8 x 5.3 in)	11.2 (24.7 lb)	0.015 (0.5 cu.ft.)	Body : WH PSYL PSOR PSRD PSBL PSGN BK

Carton size and weight vary according to cable length. Figures shown in the table are for the standard cable length packaging. Please contact us for additional details.

For colour customisations, kindly contact us for further information.

Updated Date : 29 July 2025