



INDICATIVE SEAL

MEGA HASP PADLOCK (MEHAP)

Application Seal

Visible and vibrant locking insert for versatility and product security.

Mega Hasp Padlock features a stainless-steel insert for effective locking for different applications. The seal is slim and space-saving, hence ideal for sealing on roughly handled applications. It has a clear body and vibrant colour insert which allow quick inspection of locking and colour coding to ease operation.

These seals include the BioSphere bio-additive.

To provide eco-conscious solutions on a wide array of applications, all Mega Fortris' security seal product lines with plastic content will include the BioSphere bio-additive from 13th May 2024.

Applications:

- Authentication Tagging
- Aircraft Carts
- Retail Applications
- F&B Applications



Our biodegradable plastic additives go deeper, allowing microbes to consume the C-C bonds within plastic's structure at a macromolecular level. This increases the surface area of plastic products and enables plastophilic microbes to attach to the polymer's newfound cavities. So, unlike regular plastic that can sit in a landfill for hundreds or thousands of years, plastic enhanced with BioSphere attracts over 600 different types of microbes that effectively digest and consume it.

PREVENTION · PROTECTION · PEACE OF MIND



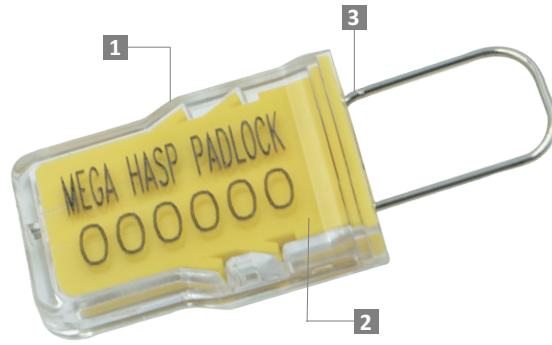

- 1** The Mega Hasp Padlock is moulded with high-impact clear PC plastic material and stainless-steel spring insert to ensure light and durable quality for different applications and clear evidence of tampering.
- 2** A wide range of vibrant pastel colour inserts complement the clear padlock body for inspection and colour coding to ease operation.
- 3** One-way snap-on locking mechanism is embedded for fast and easy application, as well as quick evidence of tampering or removal at the noticeable breaking point.
- 4** Irreversible identifiers such as name, logo, barcode, serial number and QR code are laser-marked on the body.
- 5** These seals include the BioSphere bio-additive.

LASER MARKING OPTION

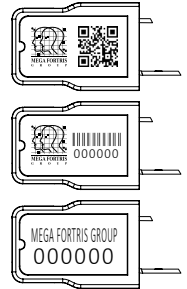

VIEW APPLICATION VIDEO

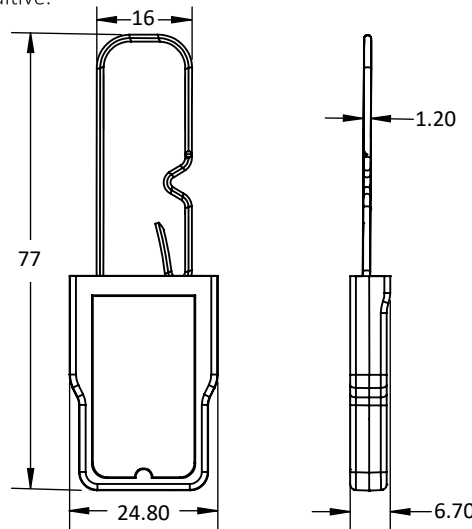
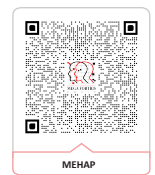

TECHNICAL SPECIFICATIONS

| PRODUCT - MEGA HASP PADLOCK (MEHAP) | | | | | | |
|-------------------------------------|---|----------------|-------------------|------------------------|------------------------------|--|
| Code | Material | Locking Length | Locking Size | Tensile Strength | Marking Area | Max Marking Digits |
| MEHAP | Plastic : High-impact Polycarbonate (PC) <i>Temperature Range:</i> -20°C to 80°C Spring : Stainless Steel (SUS304) | 41 (1.6 in) | 13.6 (0.54 in) | >30 kgf (>66.1 lbf) | 16 x 24 mm (0.6 x 0.9 in) | Serial no : 9 Barcode : 9 |

| PACKAGING | | | | | |
|-----------|----------|---|-------------------|--------------------------|---|
| Carton | Quantity | Dimensions (mm) | Gross Weight (kg) | Volume (m ³) | Standard Pastel Colours |
| Inner | 1000 | 465 x 260 x 190 (18.3 x 10.2 x 7.5 in) | 6.2 (13.7 lb) | 0.023 (0.812 cu.ft) | Body : FR Insert : WH PSYL PSOR PSRD PSBL PSGN BK |

For colour customisations, kindly contact us for further information.

Updated Date : 29 July 2025