



MEGA FORTRIS
G R O U P

INDICATIVE SEAL

MEGA TWISTER BARCODE HORIZONTAL (MTW BH)

MEGA TWISTER BARCODE HORIZONTAL - PP (MTW BH - PP)

Application Seal

Fundamental and feasible piece for quick utility security.

Mega Twister Barcode Horizontal is an improved Mega Twister Seal designed for cost efficiency without degrading the quality. It is an elementary utility seal designed with essential tamper-evident features and it comes in two versions. Mega Twister Barcode Horizontal has a translucent body for quick inspection of the twister insert sealing, where colour coded inserts and its ample identifier marking area eases operations. Conversely, Mega Twister Barcode Horizontal - PP has a polypropylene coloured body which is designed to be chemical resistant. The seal is small in size and versatile for any securing and identifying purposes. These seals include the BioSphere bio-additive.

To provide eco-conscious solutions on a wide array of applications, all Mega Fortris' security seal product lines with plastic content will include the BioSphere bio-additive from 13th May 2024.

Applications:

- Utility Meters & Scales
- Chemical and Oil Refinery
- Transportation
- Banking



Our biodegradable plastic additives go deeper, allowing microbes to consume the C-C bonds within plastic's structure at a macromolecular level. This increases the surface area of plastic products and enables plastophilic microbes to attach to the polymer's newfound cavities. So, unlike regular plastic that can sit in a landfill for hundreds or thousands of years, plastic enhanced with BioSphere attracts over 600 different types of microbes that effectively digest and consume it.

PREVENTION · PROTECTION · PEACE OF MIND



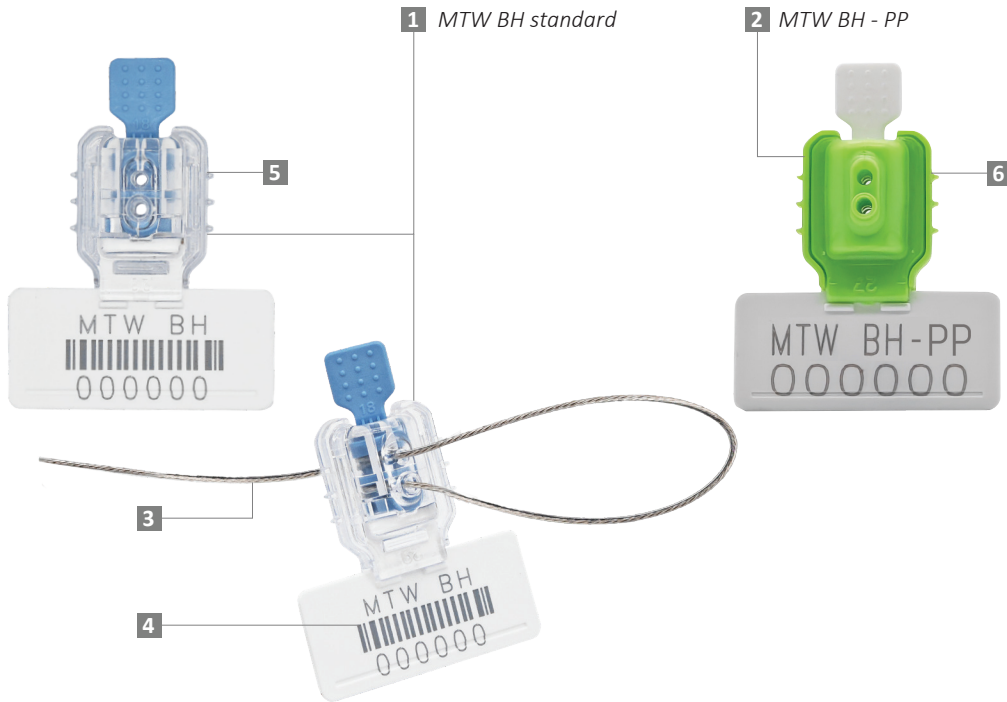

LASER MARKING OPTION

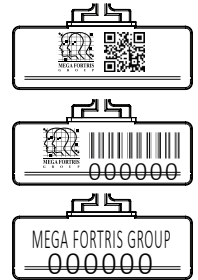

VIEW APPLICATION VIDEO



- 1 The Mega Twister Barcode Horizontal is produced with a frosted-coloured body and a twister locking insert. The frosted-coloured plastic body is translucent and allows a clear view of the locking and evidence of tampering.
- 2 Mega Twister Barcode Horizontal - PP comes with a coloured body and is designed to be chemical resistant.
- 3 The standard wire for various applications is stainless steel (SS) coated wire. Other wire types are available upon request. With the wires, the twister locking mechanism ensures quick and tight securing of the security seals.
- 4 A marking area flap is placed on the bottom for irreversible laser marking of identifiers such as name, logo, barcode, serial number and QR code. Horizontal marking area depends on customer application and requirements.
- 5 For Mega Twister Barcode Horizontal, colour coding is possible with a combination of the frosted plastic body and our offered colour choices for the vibrant colour insert.
- 6 For Mega Twister Barcode Horizontal - PP, colour coding is possible with a combination of our offered colour choices for the body and white insert.
- 7 These seals include the BioSphere bio-additive.

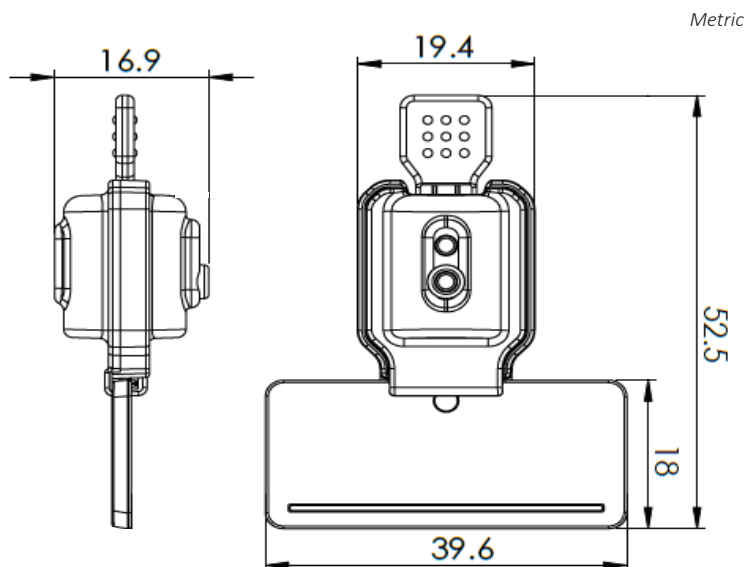

Updated Date : 29 July 2025

TECHNICAL SPECIFICATIONS

PRODUCT - MEGA TWISTER BARCODE HORIZONTAL (MTW BH) & MEGA TWISTER BARCODE HORIZONTAL PP (MTW BH - PP)

Code	Material	Locking Length (mm)	Locking Size (mm)	Tensile Strength (kgf)	Marking Area (mm)	Max Marking Digits
MTW BH	Plastic body: Polycarbonate (PC) Temperature range: -40°C to 85°C Marking Flap: Polypropylene (PP) Temperature Range: -5°C to 80°C Plastic insert: Acetal (POM) Temperature range: -40°C to 120°C Cable: Plastic-coated Stainless Steel 304 (SUS 304)	250 (9.8 in)	∅ 0.8 (0.03 in)	>25 (>55 lbf)	12 x 36 (0.47 x 1.4in)	Serial no : 13 Barcode : 13
	Plastic body: Polypropylene (PP) Temperature Range: -5°C to 80°C Marking Flap: Polypropylene (PP) Temperature Range: -5°C to 80°C Plastic insert: Acetal (POM) Temperature range: -40°C to 120°C Cable: Plastic-coated Stainless Steel 304 (SUS 304)		∅ 1.8 - 2.0 (0.071 in - 0.078 in)			

PACKAGING

Carton	Quantity	Dimensions (mm)	Gross Weight (kg)	Volume (m ³)	Standard Colours
Inner	1000	284 x 254 x 299 (11.2 x 10 x 11.8 in)	5 (11.0 lb)	0.0215 (0.76 cu.ft)	MTW BH Body : TR FR Marking Flap : WH Insert : WH YL OR GN RD BL BK

MTW BH - PP

Body : WH PSYL PSOR PSRD PSBL PSGN
BK TR

Marking Flap : WH

Insert : WH

For colour customisations, kindly contact us for further information.

Updated Date : 29 July 2025