



MEGA FORTRIS
G R O U P

INDICATIVE SEAL
MEGA SPINNER (MSP)
Application Seal

Comprehensive features in one for space saving security.

The Mega Spinner seal is the only utility seal with a round identifier area across its range. This allows the seal to be utilized for space optimization without compromising its security capability. The seal has a translucent body for quick inspection of the twister insert sealing. Ease of operation is achievable with identifiers and colour coded inserts. These seals include the BioSphere bio-additive.

To provide eco-conscious solutions on a wide array of applications, all Mega Fortris' security seal product lines with plastic content will include the BioSphere bio-additive from 13th May 2024.

Applications:

- Utility Meters & Scales
- Chemical and Oil Refinery
- Transportation
- Banking



Our biodegradable plastic additives go deeper, allowing microbes to consume the C-C bonds within plastic's structure at a macromolecular level. This increases the surface area of plastic products and enables plastophilic microbes to attach to the polymer's newfound cavities. So, unlike regular plastic that can sit in a landfill for hundreds or thousands of years, plastic enhanced with BioSphere attracts over 600 different types of microbes that effectively digest and consume it.

PREVENTION · PROTECTION · PEACE OF MIND





LASER MARKING OPTION

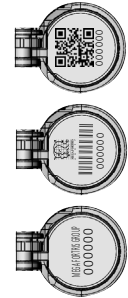

- 1 The Mega Spinner is moulded with a twister locking insert and white cap ultrasonically and heat staking welded in a plastic translucent body for a clear view of the locking and evidence of tampering.
- 2 Stainless steel wire is required for the twister locking to achieve quick sealing and tight securing on the latches.
- 3 A round marking area flap is placed on the side for irreversible laser marking of identifiers such as name, logo, number and QR code.
- 4 Colour coding is possible with a combination of translucent plastic body and vibrant colour insert, which is available in a wide range of choices.
- 5 These seals include the BioSphere bio-additive.

VIEW APPLICATION GIF

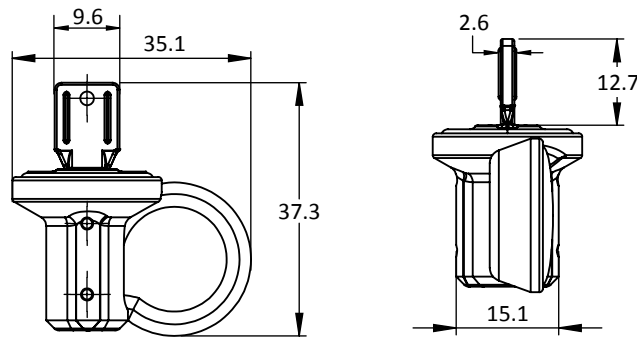
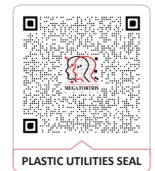

TECHNICAL SPECIFICATIONS

PRODUCT - MEGA SPINNER (MSP)

Code	Material	Locking Length	Locking Size	Tensile Strength	Marking Area	Max Marking Digits
MSP	Plastic body: Acrylic Temperature Range: -20°C to 70°C Plastic insert: Acetal (POM) Temperature Range: -40°C to 120°C Marking insert: Polypropylene (PP) Cable: Plastic-coated Stainless Steel 304 (SUS 304)	250 mm (9.8 in)	Ø 0.8 mm (0.03 in)	>30 kgf (>66 lbf)	Ø 12 mm (0.5 in)	Serial no: 6 QR code

PACKAGING

Carton	Quantity	Dimensions (mm)	Gross Weight (kg)	Volume (m ³)	Standard Colours
Inner	1000	With pre-cut wire: 454 x 214 x 244 mm (17.8 x 8.4 x 9.6 in)	7 (15.4 lb)	0.024 (0.837 cu. ft.)	Body : FR Cover : FR Cap : WH Insert : WH YL OR GN RD BL BK Marking insert : WH PSYL PSOR PSRD PSBL PSGN BK
		With wire twisting: 465 x 260 x 190 mm (18.3 x 10.2 x 7.5 in)		0.023 (0.023 cu. ft.)	

For colour customisations, kindly contact us for further information.

Updated Date : 13 May 2024